



# Standard Test Methods for Evaporation Rates of Volatile Liquids by Shell Thin-Film Evaporometer<sup>1</sup>

This standard is issued under the fixed designation D3539; the number immediately following the designation indicates the year of original adoption or, in the case of revision, the year of last revision. A number in parentheses indicates the year of last reapproval. A superscript epsilon ( $\epsilon$ ) indicates an editorial change since the last revision or reapproval.

*This standard has been approved for use by agencies of the U.S. Department of Defense.*

## 1. Scope

1.1 These test methods cover the determination of the rate of evaporation of volatile liquids of low viscosity using the Shell thin-film evaporometer. These test methods have been applied to a wide range of volatile liquids, including paint, varnish, and lacquer solvents and thinners to various hydrocarbons and to insecticide spray-base oils.

1.2 The test methods for the determination of evaporation rate using the thin-film evaporometer are:

	Sections
Test Method A <sup>2,3</sup> —Manual Recording	5 – 11
Test Method B—Automatic Recording	12 – 17

1.3 These test methods are limited only by the viscosity of the volatile liquid which must be sufficiently low to permit the dispensing of an accurately measured specimen from a syringe.

1.4 The values stated in SI units are to be regarded as the standard. The values given in parentheses are for information only.

1.5 *This standard does not purport to address all of the safety concerns, if any, associated with its use. It is the responsibility of the user of this standard to establish appropriate safety and health practices and determine the applicability of regulatory limitations prior to use.* Specific hazard statements are given in 5.2 and 5.6.

<sup>1</sup> These test methods are under the jurisdiction of ASTM Committee D01 on Paint and Related Coatings, Materials, and Applications and are the direct responsibility of Subcommittee D01.24 on Physical Properties of Liquid Paints and Paint Materials.

Current edition approved Feb. 1, 2011. Published March 2011. Originally approved in 1976. Last previous edition approved in 2004 as D3539 – 87 (2004). DOI: 10.1520/D3539-11.

<sup>2</sup> These test methods are essentially the same as the one developed by the New York Society for Paint Technology. The Precision section was added by ASTM Subcommittee D01.24 and is based upon the data of the New York Society for Paint Technology.

<sup>3</sup> See “Comparative Evaporation Rates of Solvents: II,” New York Club, Technical Subcommittee No. 66, *Official Digest*, 28, No. 382, 1956, p. 1060.

## 2. Referenced Documents

2.1 *ASTM Standards*:<sup>4</sup>

D891 Test Methods for Specific Gravity, Apparent, of Liquid Industrial Chemicals

E1 Specification for ASTM Liquid-in-Glass Thermometers

## 3. Summary of Test Methods

3.1 A known volume of liquid is spread on a known area of filter paper that is suspended from a sensitive balance in a cabinet. Dried air or nitrogen at 25°C is passed through the cabinet at a known rate. The loss of weight of the filter paper/liquid is determined and plotted against time.

## 4. Significance and Use

4.1 The rate of evaporation of volatile liquids from a solution or dispersion is important because it affects the rate of deposition of a film and flow during deposition, and thereby controls the structure and appearance of the film. In the formulation of paints and related products, solvents are chosen based on the evaporation characteristics appropriate to the application technique and the curing temperature.

### TEST METHOD A—EVAPORATION RATE USING THE MANUAL THIN-FILM EVAPOROMETER

## 5. Apparatus

5.1 *Evaporometer*, thin-film evaporometer<sup>5</sup> as shown in Fig. 1 (see Annex A1).

5.2 *Constant-Temperature Cabinet* for evaporometer. (**Warning**—In instances with the solvents and other volatile materials normally tested using this apparatus and under the conditions specified in this test method, the concentration of

<sup>4</sup> For referenced ASTM standards, visit the ASTM website, [www.astm.org](http://www.astm.org), or contact ASTM Customer Service at [service@astm.org](mailto:service@astm.org). For *Annual Book of ASTM Standards* volume information, refer to the standard's Document Summary page on the ASTM website.

<sup>5</sup> The manual Shell thin-film evaporometer is no longer available.

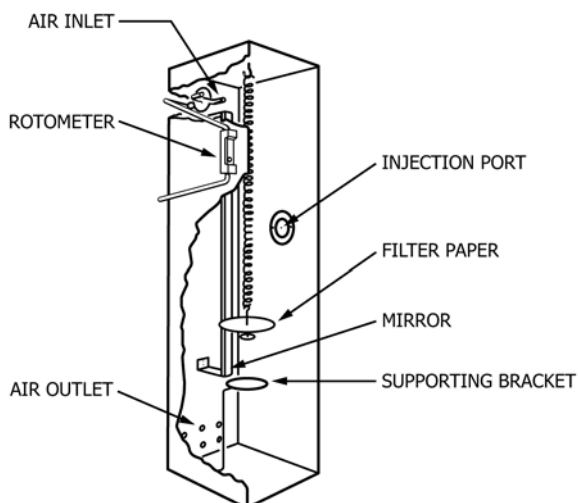

FIG. 1 Details of the Thin-Film Evaporometer

solvent or other flammable material being exhausted into the laboratory atmosphere will be significantly below any concentration that could be hazardous, that is, a lower flammable limit. However, it may be desirable to locate the instrument and cabinet in a laboratory exhaust hood if the routine handling of certain materials may present a hazard due to toxicity, extreme volatility, or flammability.)

5.3 *Interval Timer: Stopwatch or Electric Timer*—A timer that gives an audible signal at 10 or 20-s intervals and that gives a warning signal approximately 3 s before the end of the interval is preferred.

5.4 *Filter Paper Disk*—Fast, open-textured filter paper, 90 mm in diameter, with a circle approximately 60 mm in diameter (and concentric with the edge) lightly drawn on the paper with a pencil.

5.5 *Syringe*—A 1.00-mL hypodermic syringe equipped with a 225-mm needle of 1.3-mm outside diameter stainless steel tubing.<sup>6</sup> Due to manufacturing variations, the syringe should be calibrated before use.

5.6 *Dehumidification Equipment*—A suggested setup is given in a schematic diagram, Fig. 2. (**Warning**—Use of this dehumidification apparatus requires the safety practices relative to the handling, use, and disposal of hazardous acids and caustics be observed. When handling these materials, protective eye or face shields, or both, and protective clothing are recommended.)

5.7 *Hygrometer (or other humidity-sensing device)*, capable of indicating low humidities.

5.8 *Thermometers*, of suitable accuracy such as ASTM Bomb Calorimeter thermometer 56C having a range from 19 to 35°C, subdivisions 0.02°C or Thermometer 56F (66 to 95°F with 0.05°F subdivisions), and conforming to the requirements of Specification E1. In addition, temperature measuring de-

vices that do not contain mercury such as liquid-in-glass thermometers, thermocouples, or platinum resistance thermometers that provide equivalent or better accuracy and precision and cover the temperature range for thermometers 56C or 56F may be used.

## 6. Preparation of Evaporometer

6.1 Place the filter paper disk on the wire support, threading the hook through a small hole in the center of the paper. Attach the hook to the steel spring below the sighting disk and allow the paper and the paper support to hang therefrom.

6.2 Close the evaporometer and cabinet doors and allow the temperature in both chambers and the humidity to equilibrate at the following test conditions:

Cabinet and evaporation temperature:  $25 \pm 0.25^\circ\text{C}$  ( $77 \pm 0.5^\circ\text{F}$ )  
Evaporometer humidity: 0 to 5 % relative humidity

Approximately 2 h are required for the humidity to drop to less than 5 %.

6.3 Adjust the air flow to 21 L/min (center of ball float opposite correct mark on the rotometer scale).

## 7. Conditioning

7.1 Bring the sample or a portion of it to an equilibrium temperature of  $25 \pm 0.5^\circ\text{C}$  ( $77 \pm 1.0^\circ\text{F}$ ) in a constant-temperature bath. Determine the specific gravity of the sample at this temperature in accordance with Test Methods D891.

## 8. Procedure

8.1 Record the position of the filter paper as indicated by alignment of the sighting disk with its mirror image. This is the no-load position.

8.2 Raise the wire mesh bracket until the bottom of the disk support rests lightly on it.

8.3 Withdraw into the syringe 0.70 mL of the solvent which is at  $25 \pm 0.5^\circ\text{C}$  ( $77 \pm 1.0^\circ\text{F}$ ). Make certain that all air bubbles are expelled from the syringe and the needle before application of the specimen to the filter paper.

8.4 Insert the hypodermic needle into the small opening on the right-hand side of the instrument and position the needle tip so that it almost touches the disk and is just over the line that was drawn.

8.5 Start applying the solvent to the disk. As the first drop hits the disk, start the timer. The solvent should be applied at a uniform rate in  $\pm 2$  s and as evenly as possible along the drawn line. To ensure consistent specimen size, touch the tip of the hypodermic needle to the filter paper to dispense the last drop of solvent.

8.6 Immediately lower the wire mesh bracket away from the disk support. Obtain the first reading of the position of the sighting disk at 40 s and then every 20 s. Record the time and the scale reading on the report form. A sample report form is shown in Annex A2.

NOTE 1—With very slow evaporating solvents, it is not necessary to take readings as often as every 20 s. The operator can determine a suitable time interval after the first 200 s.

<sup>6</sup> Syringe: Becton, Dickinson and Co., No. 1YT available from Fisher Scientific Co. Needle: Special Syringe Needle Type LNR, 18-gage, 9-in. long blunt round end, no bevel available on special order from Becton, Dickinson and Co. through Fisher Scientific Co., 711 Forbes Ave., Pittsburgh, PA 15239.

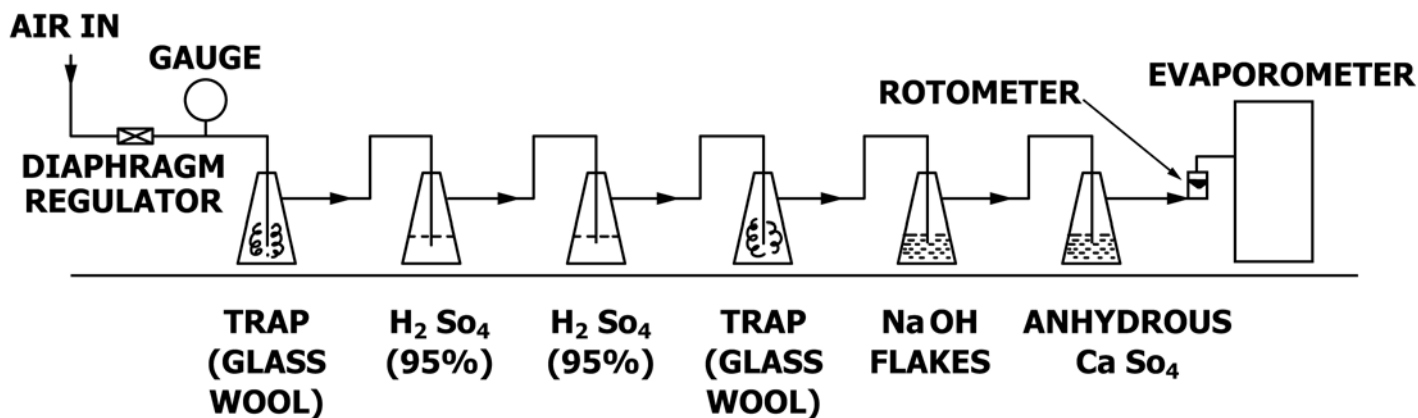

NOTE 1—One-litre flasks should be used throughout.

FIG. 2 Diagram of Dehumidification Apparatus

8.7 Stop the timer when the sighting disk has returned to the original unloaded position.

NOTE 2—The filter paper may be reused provided the solvent leaves no appreciable residue in evaporating.

### 9. Calculation

9.1 Calculate the evaporation rate as follows:

$$ER = \frac{C}{S} \times 100(B - Z) \quad (1)$$

where:

- $S$  =  $V \times D$  and  $Z = N - (S/C)$
- $ER$  = evaporation rate, wt %,
- $C$  = spring constant, cm/g elongation,
- $S$  = specimen weight,
- $V$  = 0.70-mL aliquot volatile liquid at  $25 \pm 0.5^\circ\text{C}$  ( $77 \pm 1.0^\circ\text{F}$ ),
- $D$  = density of volatile liquid at  $25 \pm 0.5^\circ\text{C}$  ( $77 \pm 1.0^\circ\text{F}$ ) (Taken as equivalent to specific gravity but with units of mL/g)
- $B$  = scale reading taken during evaporation of aliquot,
- $Z$  = zero percent evaporated, scale reading =  $N - (S/C)$ , and
- $N$  = no-load scale reading (100 % evaporated reading).

9.2 Plot the percent evaporated against elapsed time in seconds and draw a smooth curve through the points. From the curve, determine at 10 weight % increments to 90 % and for 95 and 100 % evaporation the time in seconds to the nearest value as follows:

Approximate Elapsed Time to 100 % Evaporated Point, s	Report to Nearest Indicated Value, s
Less than 300	1
300 to 600	5
600 to 1800	10
1800 to 3600	30
3600 to 7200	60
More than 7200	nearest 2 % of indicated value

NOTE 3—The curve drawn through the various points should pass

through zero or the origin. If it passes to the right of the origin, the delivery time was in excess of 12 s or an aliquot larger than that specified was delivered. If it passes to the left of the origin, then the aliquot was smaller than specified.

### 10. Report

10.1 Report the elapsed time in seconds at 10 weight % intervals through 90 % and for 95 and 100 % evaporation, and the relative evaporation rate (*n*-butyl acetate = 1.0). Relative evaporation rate is calculated from the 90 weight % evaporated times for the test solvent and for *n*-butyl acetate (99 % ester).

### 11. Precision<sup>7</sup>

11.1 On the basis of an interlaboratory study of the test method in which operators in six laboratories determined the 90 % evaporation point of six solvents covering a broad range in evaporation rate, the between-laboratories coefficient of variation was found to be 6.3 % relative at 24 df after discarding two divergent values. On the basis of the results obtained by three laboratories on three of the solvents having 90 % evaporated times of 200 to 600 s, the within-laboratory coefficient of variation was found to be 0.83 % relative at 18 df. Based on these coefficients, the following criteria should be used for judging the acceptability of results at the 95 % confidence level:

11.1.1 *Repeatability*—For solvents with 90 % evaporation times of 200 to 600 s, two results, each the mean of two determinations, obtained by the same operator on different days should be considered suspect if they differ by more than 2.5 %.

11.1.2 *Reproducibility*—Two results, each the mean of two determinations, obtained by operators in different laboratories should be considered suspect if they differ by more than 18.2 %.

<sup>7</sup> Supporting data have been filed at ASTM International Headquarters and may be obtained by requesting Research Report RR:D01-1003. Contact ASTM Customer Service at service@astm.org.